

MSS Hand Stamp and Type

Monode™ Steel Stamp

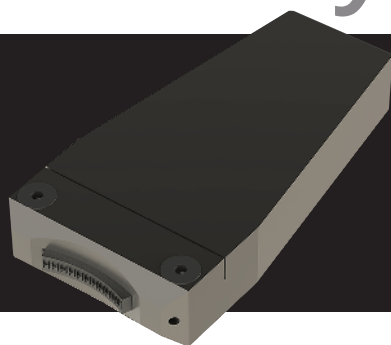

Hand Stamps

Monode Saf-t Grip Heavy Duty Hand Stamps

Our top quality line of stamps features:

- Heavy Duty Shank
- Longer Shank
- Saf-T Sleeve
- Size Color Coded



Color Code	Character Size	Steel Size, Inches		27 Pc. Letter Set Part No.	9 Pc. Letter Set Part No.
		Square	Length		
Lemon Yellow	1/32"	1/4"	2-5/8"	10031/A-Z	10031/0-8
Light Green	3/64"	1/4"	2-5/8"	10046/A-Z	10046/0-8
Brilliant Green	1/16"	5/16"	2-5/8"	10062/A-Z	10062/0-8
Medium Yellow	3/32"	5/16"	2-5/8"	10093/A-Z	10093/0-8
Ultra Blue	1/8"	5/16"	2-5/8"	10125/A-Z	10125/0-8
Brilliant Blue	5/32"	3/8"	2-3/4"	10156/A-Z	10156/0-8
Carmine	3/16"	3/8"	2-3/4"	10187/A-Z	10187/0-4
Red	1/4"	7/16"	2-7/8"	10250/A-Z	10250/0-8
Orange	5/16"	1/2"	2-7/8"	10312/A-Z	10312/0-8
Brown	3/8"	5/8"	3-15/16"	10375/A-Z	10375/0-8
Black	1/2"	5/8"	3-15/16"	10500/A-Z	10500/0-8

Hand Stamps

Monode Economy Hand Stamps

Lighter application stamps that feature:

- Smaller Shank
- Machine Formed Characters
- Low Cost



Character Size	Steel Size, Inches		27 Pc. Letter Set Part No.	9 Pc. Letter Set Part No.
	Square	Length		
1/16"	1/4"	2-3/8"	20062/A-Z	20062/0-8
3/32"	1/4"	2-3/8"	20093/A-Z	20093/0-8
1/8"	1/4"	2-3/8"	20125/A-Z	20125/0-8
3/16"	5/16"	2-7/16"	20187/A-Z	20187/0-8
1/4"	3/8"	2-9/16"	20250/A-Z	20250/0-8
3/8"	1/2"	2-7/8"	20375/A-Z	20375/0-8
1/2"	5/8"	2-7/8"	20500/A-Z	20500/0-8

Pressure Data For Marking

The tonnage requirements for marking mild steel:

Multiply the proper tonnage (see character size chart) X the number of characters to be stamped.

*To determine pressures for aluminum or brass multiply the above tonnage by the 0.7. For carbon steel, multiply by 1.5.

** To determine other impression depths, multiply the tonnage by the following:

1/2 of depth 0.7

2 times depth ...1.3

3 times depth ...1.7

Character Size	Estimated Pressure to Stamp One Character*	Depth of Impression*
1/16" - .062	.25 ton	.003
3/32" - .093	.50 ton	.0045
1/8" - .125	.75 ton	.006
5/32" - .156	1.00 ton	.007
3/16" - .187	1.88 ton	.008
1/4" - .250	2.10 ton	.010
5/16" - .312	3.00 ton	.013
3/8" - .375	4.00 ton	.016
7/16" - .437	4.75 ton	.016
1/2" - .500	5.70 ton	.017
5/8" - .625	7.50 ton	.020
3/4" - .750	9.25 ton	.020
7/8" - .875	11.00 ton	.020
1" - 1.00	13.00 ton	.020

Type

- Sharp face gothic characters.
- Heavy duty and industrial use.
- Standard sizes stocked.*

Mac-Type

High quality interchangeable straight and straight groove type manufactured for use in hand and press holders

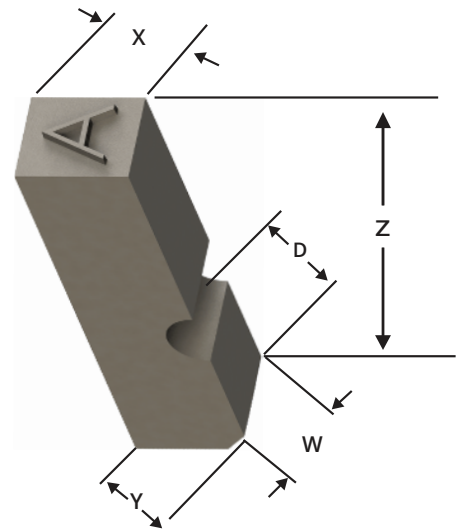
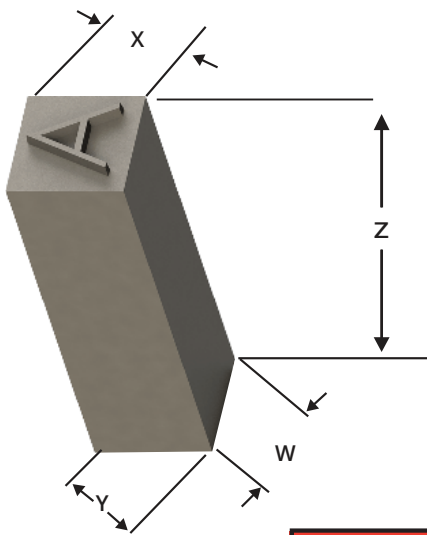

Character Size	Type Dimensions
3/64"	1/16 x 1/4 x 7/8*
1/16"	1/16 x 1/4 x 7/8*
3/32"	3/32 x 1/4 x 7/8*
1/8"	1/8 x 1/4 x 7/8*
5/32"	5/32 x 1/4 x 7/8*
3/16"	3/16 x 5/16 x 7/8*
1/4"	1/4 x 3/8 x 7/8*

* Length may vary

Monode Steel Stamp Wedge Type

Precision ground knurl type for standard 3 inch diameter holders. X=character size

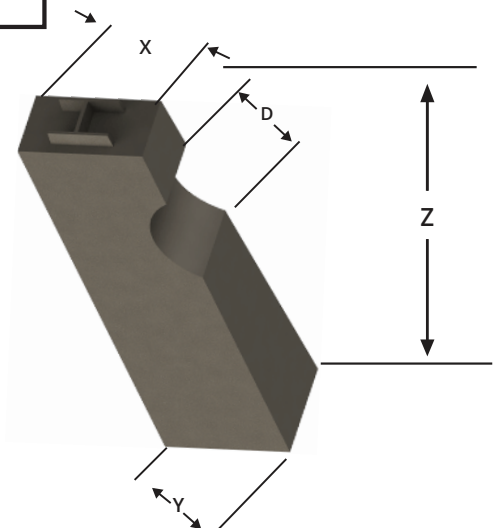

Hand/Press Type Holders

Monode's industrial type holders can be ordered for press operations or hand marking. Heavy duty shanks are press fit and pinned to ensure positive pressure transfer as well as non rotating alignment.

Specify shank size diameter and length for press holders.

Model	Size of Opening	Capacity by Type Size		
		1/16	3/32	1/8
143410	1/4" x 3/4" x 1"	12	8	6
141010	1/4" x 1" x 1"	16	10	8
141810	1/4" x 1-1/8" x 1"	18	12	9
141410	1/4" x 1-1/4" x 1"	20	13	10
141210	1/4" x 1-1/2" x 1"	24	16	12
141310	1/4" x 1-3/4" x 1"	28	18	14
142010	1/4" x 2" x 1"	32	21	16

